

# AUTOMATION SYSTEMS FOR SLIDING GATES

Operating and installation instructions

# BRAVO524

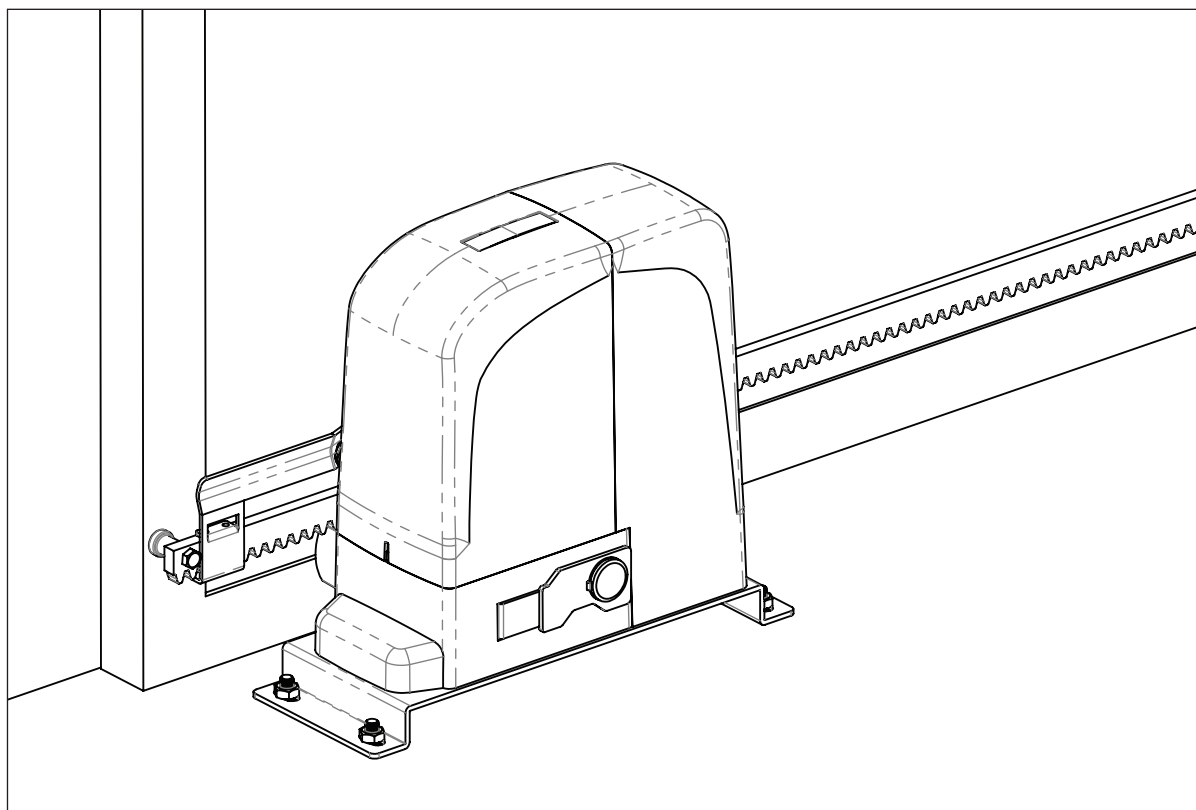

## INDEX

1) General Safety Regulations	.....	pág. 01
2) Description	.....	pág. 02
3) Technical Specifications	.....	pág. 03
4) System Description	.....	pág. 03
5) Accessories	.....	pág. 04
6) Installation Tools	.....	pág. 04
7) Installation	.....	pág. 05
8) Maintenance	.....	pág. 10
9) Repairs	.....	pág. 10

## 1) GENERAL SAFETY REGULATIONS

- 1) ATTENTION! To ensure the safety of people, it is important that you read all the following instructions. Incorrect installation or incorrect use of the product could cause serious harm to people.
- 2) Carefully read the instructions before beginning to install the product.
- 3) Do not leave packing materials (plastic, polystyrene, etc.) within reach of children as such materials are potential sources of danger.
- 4) Store these instructions for future reference.
- 5) This product was designed and built strictly for the use indicated in this documentation. Any other use, not expressly indicated here, could compromise the good condition/operation of the product and/or be a source of danger.
- 6) Manufacturer / distributor decline all liability caused by improper use or use other than that for which the automated system was intended.
- 7) Do not install the equipment in an explosive atmosphere: the presence of inflammable gas or fumes is a serious danger to safety.
- 8) The mechanical parts must conform to the provisions of Standards EN 12604 and EN12605. For non-EU countries, to obtain an adequate level of safety, the Standards mentioned above must be observed, in addition to national legal regulations.
- 9) We are not responsible for failure to observe Good Technique in the construction of the closing elements to be motorised, or for any deformation that may occur during use.
- 10) The installation must conform to Standards EN 12453 and EN 12445.
- 11) Before attempting any job on the system, cut electrical power.
- 12) Make sure that the earthing system is perfectly constructed, and connect metal parts of the means of the closure to it.
- 13) The automated system force control. Nevertheless, its tripping threshold must be checked as specified in the Standards indicated at point 10.
- 14) The safety devices (EN 12978 standard) protect any danger areas against mechanical movement risks, such as crushing, dragging, and shearing.
- 15) Use of at least one indicator-light is recommended for every system, as well as a warning sign adequately secured to the frame structure.
- 16) Manufacturer / distributor decline all liability as concerns safety and efficient operation of the automated system, if system components not produced by them.
- 17) For maintenance, strictly use original parts by us.
- 18) Do not in any way modify the components of the automated system.
- 19) The installer shall supply all information concerning manual operation of the system in case of an emergency, and shall hand over to the user the warnings handbook supplied with the product.
- 20) Do not allow children or adults to stay near the product while it is operating.
- 21) Keep remote controls or other pulse generators away from children, to prevent the automated system from being activated involuntarily.
- 22) Transit is allowed only when the gate is fully open.
- 23) The user must not attempt any kind of repair or direct action whatever and contact qualified personnel only.
- 24) Anything not expressly specified in these instructions is not permitted.

## 2) DESCRIPTION

Automated system for residential sliding gates with leaves up to 7m long and 500 kg in weight. It consists of a reversing electro-mechanical gearmotor, powered by a 24V control unit.

The automated system houses a programmable electronic control board that enables setting of function logics, work time and pause time, anti-crushing sensitivity as well as partial-opening width. The reversing system guarantees the gate will automatically lock when the motor is not operating. A release system enables the gate to be moved by hand in case of malfunction or emergency. The automated system was designed and built for controlling sliding gates. Do not use for any other purpose.

### 2.1. Description of the structure

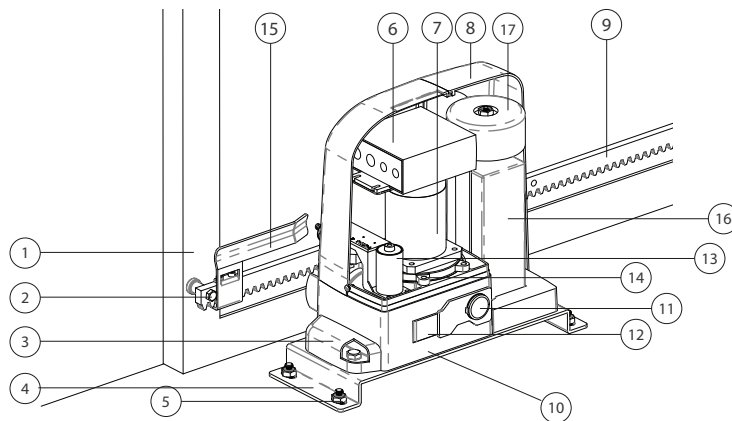

Fig. 01

- |                     |                    |                            |
|---------------------|--------------------|----------------------------|
| 1. Gate             | 7. Motor           | 13. Not applicable         |
| 2. Rack spacer      | 8. Cover           | 14. Screw                  |
| 3. Protective cover | 9. Rack            | 15. Limit switch plate     |
| 4. Foundation plate | 10. Housing        | 16. Battery (not included) |
| 5. Fixation screw   | 11. Lock           | 17. Transformer            |
| 6. Control box      | 12. Manual release | 18. Battery                |

### 2.2. Dimensions (mm)

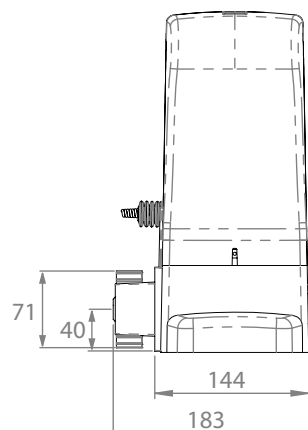
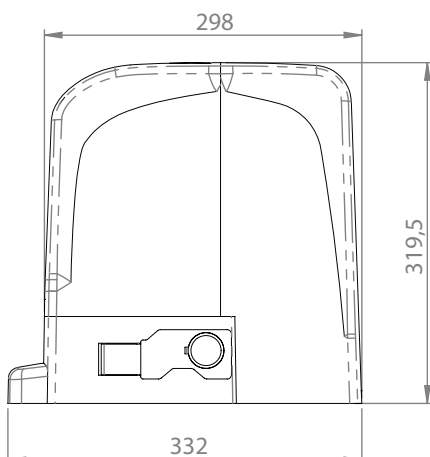

Fig. 02

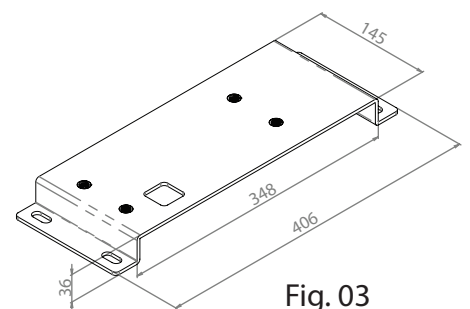

Fig. 03

### 3) TECHNICAL SPECIFICATIONS

Technical specifications of the automated operator:

Power supply (V)	230V , 50Hz
Motor	24V
Rated absorbed power (W)	120W
Max speed (m/sec)	0.16m/sec
Force	700N
Working time	-
Noise	≤ 56dB
Thermal reset	-
Operating temperature (°C)	> -25°C to < 65°C
Protection class	IP44
Thermal protection (°C)	-
Leaf max weight (Kg)	500Kg
Leaf max length (m)	7 m
Working frequency	Intensive
Capacitor	-

### 4) DESCRIPTION OF THE SYSTEM

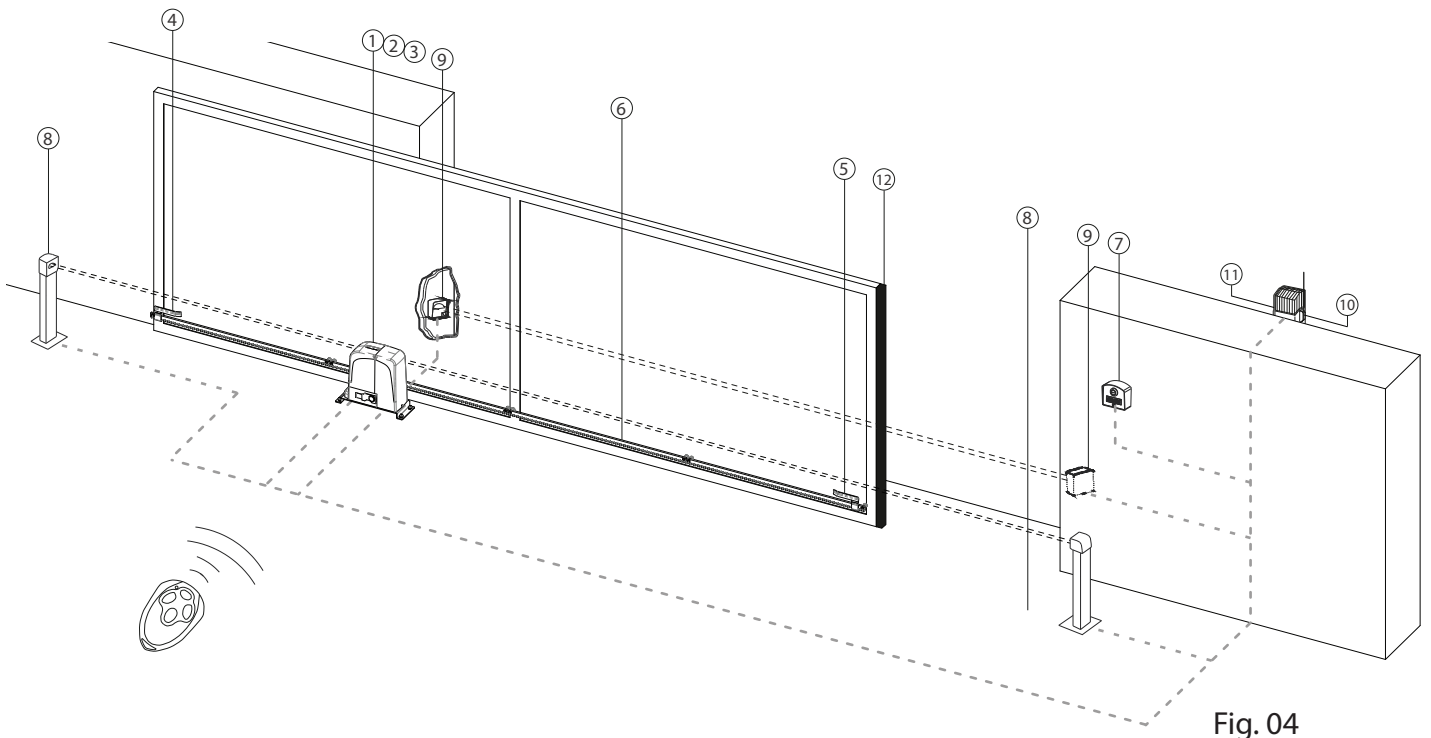

Fig. 04

- |                            |                             |                      |
|----------------------------|-----------------------------|----------------------|
| 1. Motor                   | 5. Right limit switch plate | 9. Safety photocells |
| 2. Control board           | 6. Rack                     | 10. Antenna          |
| 3. Receiver                | 7. Key selector             | 11. Warning light    |
| 4. Left limit switch plate | 8. Photocell column         | 12. Safety edge      |

Note:

- 1) To lay down electric cables, use rigid and/or flexible adequate tubes.
- 2) To avoid any kind of interference, always separate low voltage connection cables from AC230V power cables.
- 3) The description of system is standard system, but we did not provide all parts. If you want system accessories, please contact us.

## 5) ACCESSORIES

You must check the operator packing before installing the automated system.

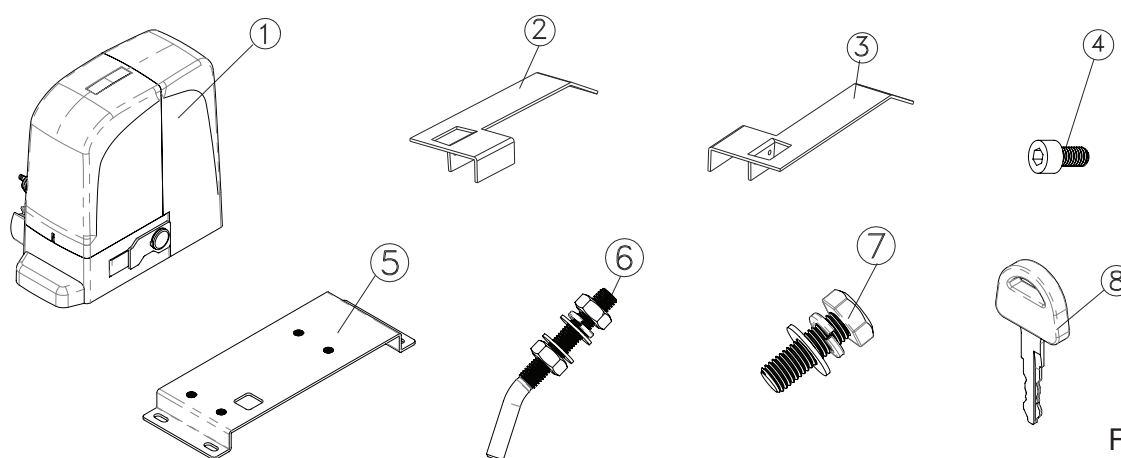

Fig. 05

No	Name	Qty	No	Name	Qty
1	Motor	1	6	Ground fixation screw	4
2	Left limit switch plate	1	7	Motor fixation screw	4
3	Right limit switch plate	1	8	Key	2
4	Screw DIN912 M5x10	4	9	User Manual	1
5	Foundation plate	1			

## 6) INSTALLATION TOOLS

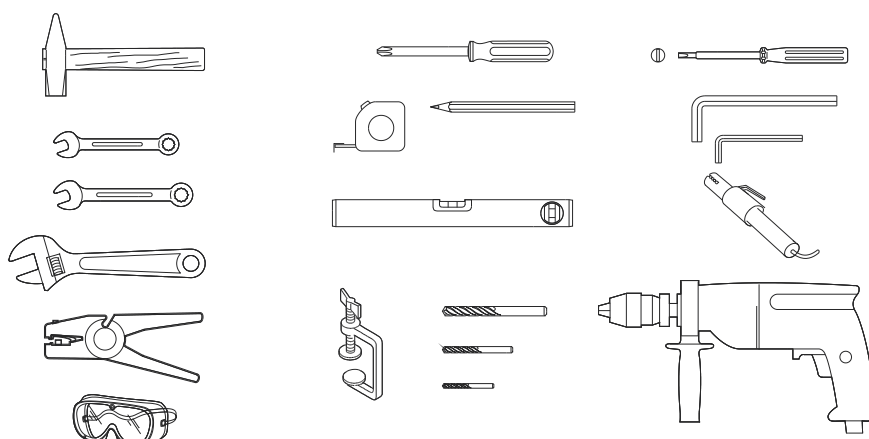

Fig. 06

## 7) INSTALATION

### 7.1. Preliminary checks

To ensure safety and an efficiently operating automated system, make sure the following conditions are applied:

- The structure of the gate must be suitable for being automated. In particular, check that the structure is sufficiently strong and rigid, and that its dimensions and weight conform to those indicated in the technical specifications;
- Make sure that the gate slides without any inclination;
- Make sure that the gate moves uniformly and correctly, without any irregular friction during its entire travel;
- The soil must permit sufficient stability for the expansion plugs securing the foundation plate;
- Remove any locks and lock bolts. We advise you to have any metalwork carried out before the automated system is installed.

### 7.2. Preparing the foundation plate

Fit the 4 supplied nuts, as shown in Fig. 07 and Fig. 08, in the 4 holes of the plate.

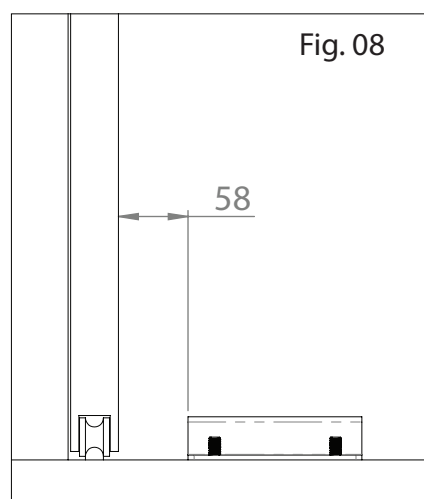
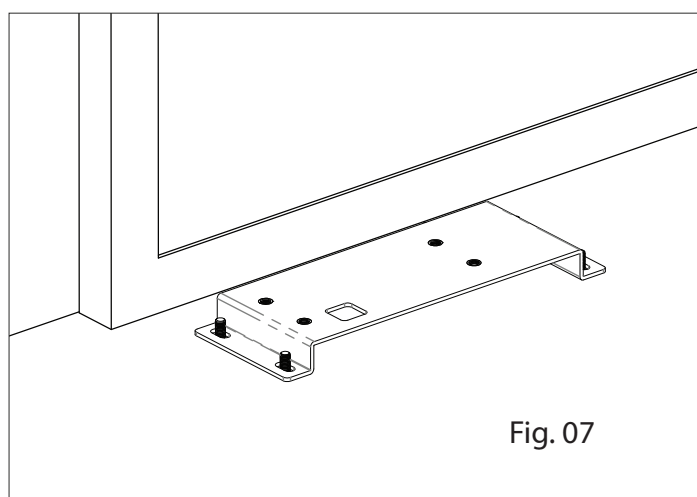

### 7.3. Preparing the foundation plate

a) The foundation plate must be located as shown in Fig. 9 a (right closing) or Fig. 9b (left closing) to ensure the rack and pinion match correctly.

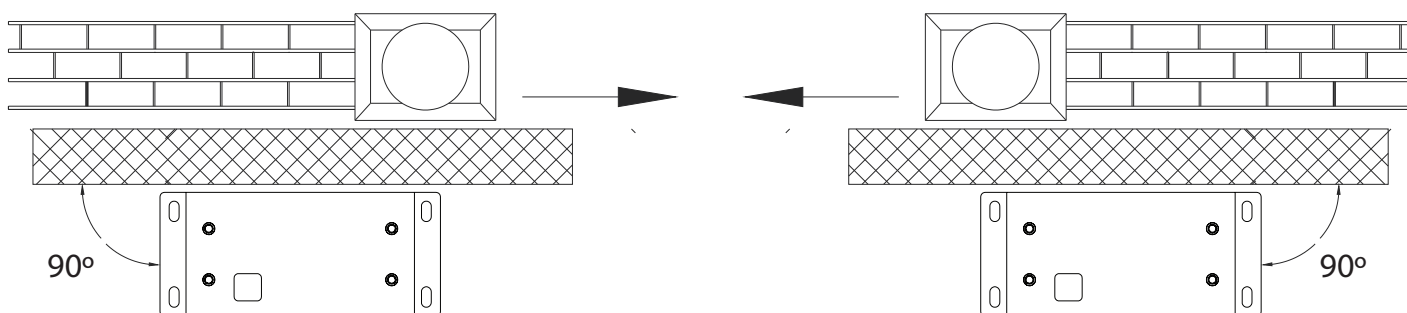
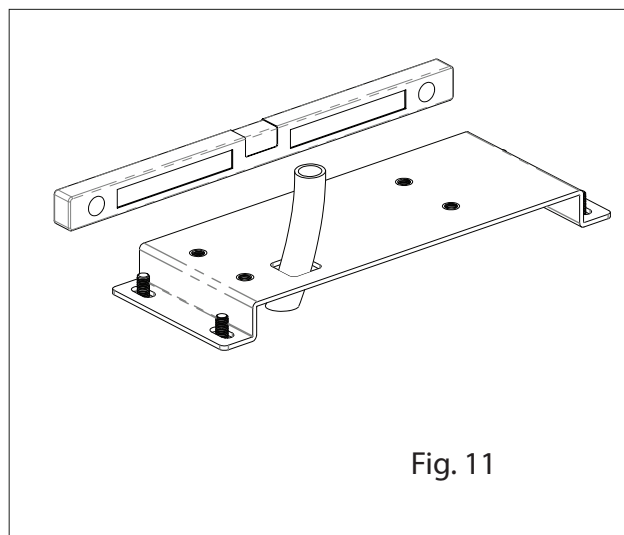
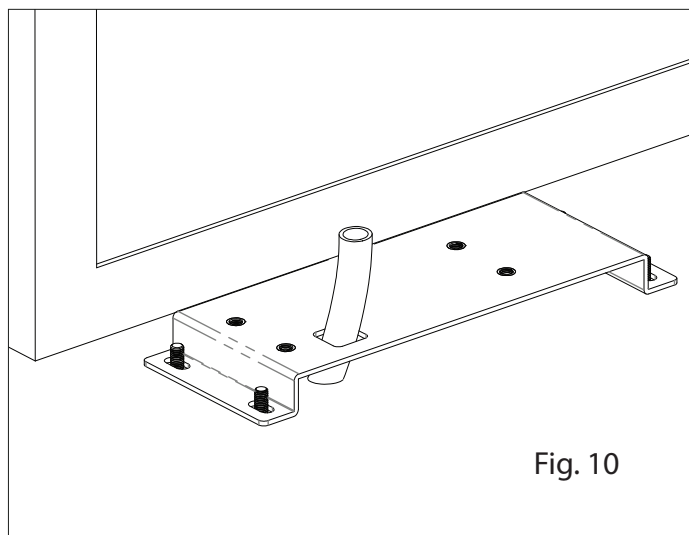

Fig. 09a

Fig. 09b

b) Put the foundation plate to the floor, using adequate expansion plugs and provide one or more tubes for routing the electric cables through the plate (Fig10 and 11). Using a level, check if the plate is perfectly horizontal.



#### 7.4. Positioning the operator

Lay the electric cables to connect motor to accessories and power supply as shown in Fig. 4. To facilitate making the connections, allow the cables to project by the required length for connection to the control board, transformer and etc (if provided). Position the operator on the plate, using the supplied screws as shown in Fig. 12.

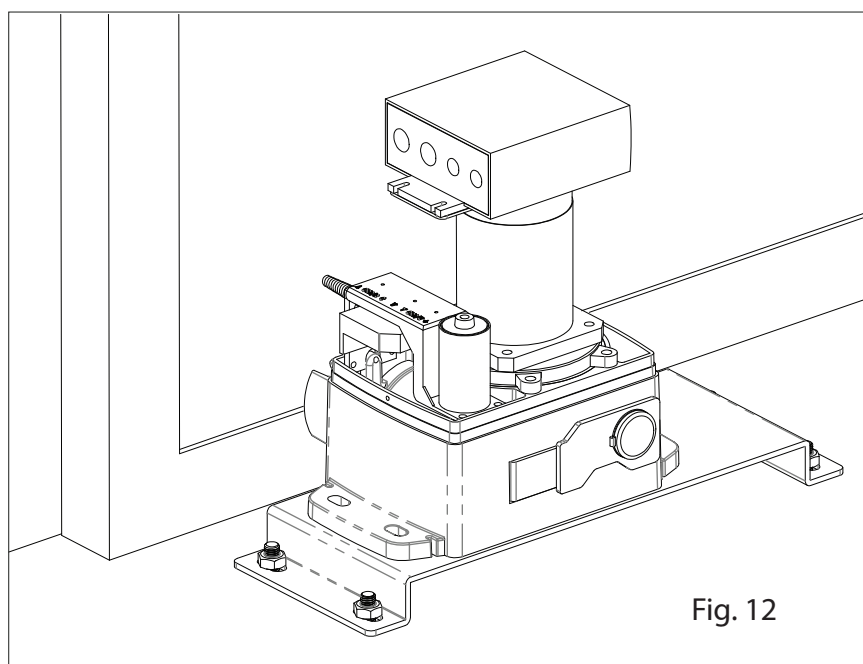



### 7.5. Adjusting the operator

Adjust the distance of the operator from the gate by referring to Fig.13.

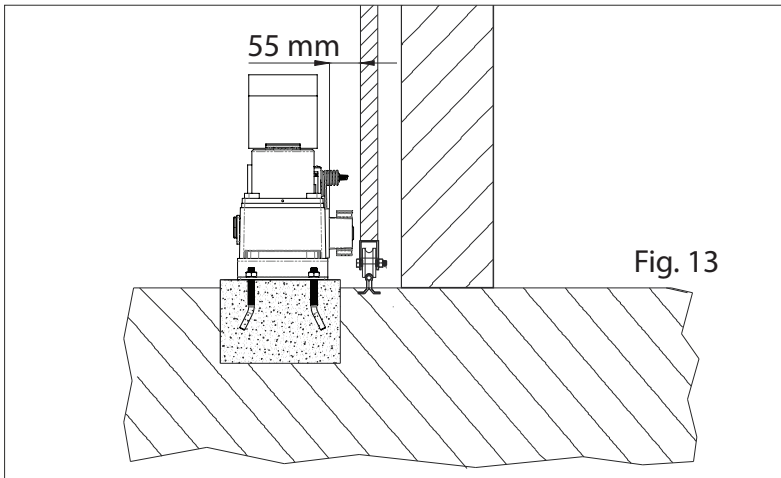

### 7.6. Fixing operator

Fix the operator slightly tightening the screws as shown in Fig. 14.

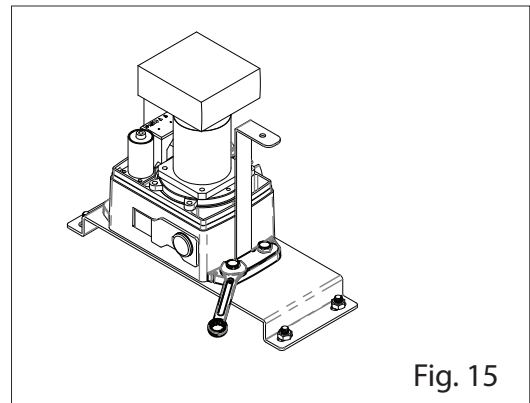
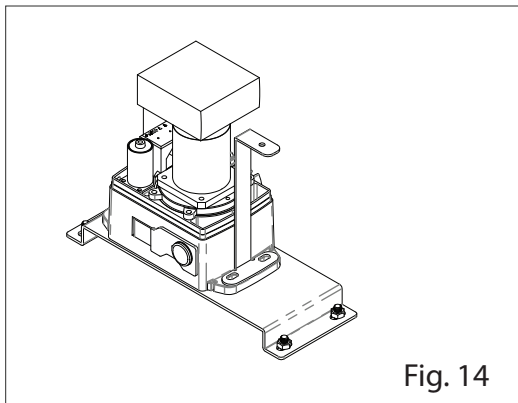

After fixing the motor install battery holder (Fig. 16), fixing the transformer with a screw and nut (Fig. 17) and the battery (Fig. 18).

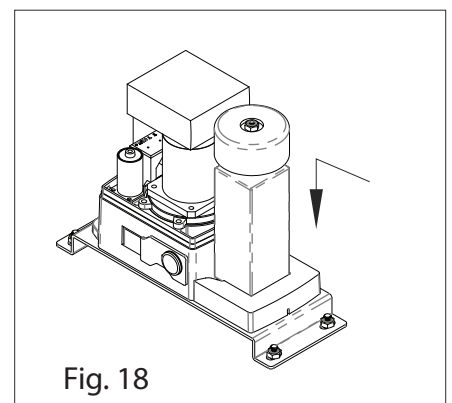
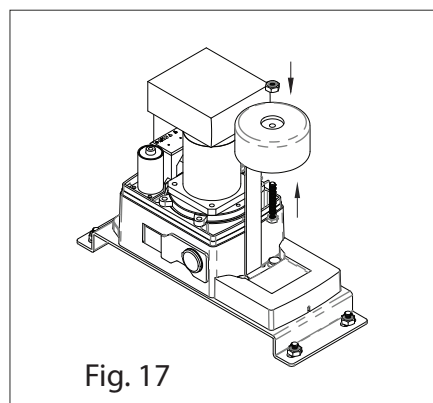
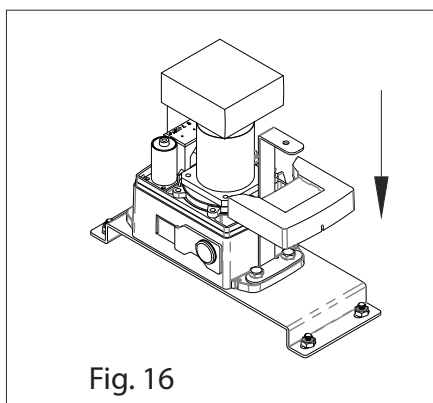

After fixing inside components, please screw the upper-cover (Fig. 19 and Fig. 20)

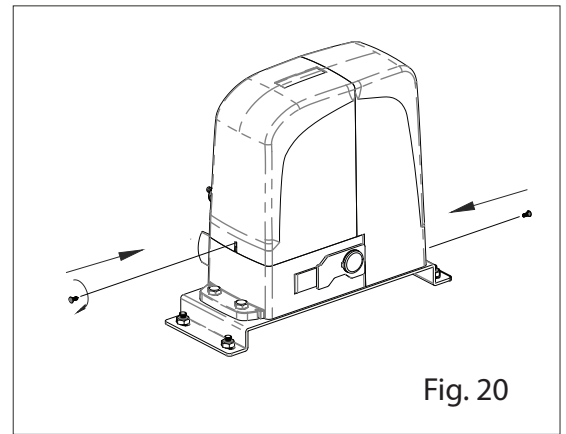
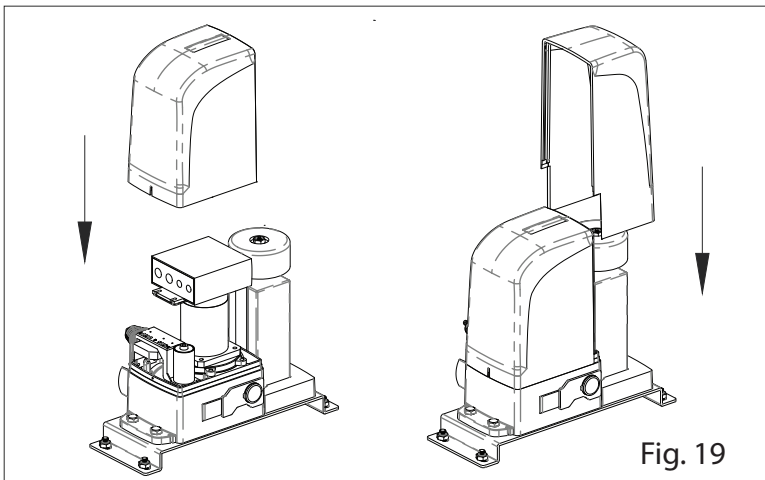

After the upper-cover fixed, please install the side-cover (Fig. 21).

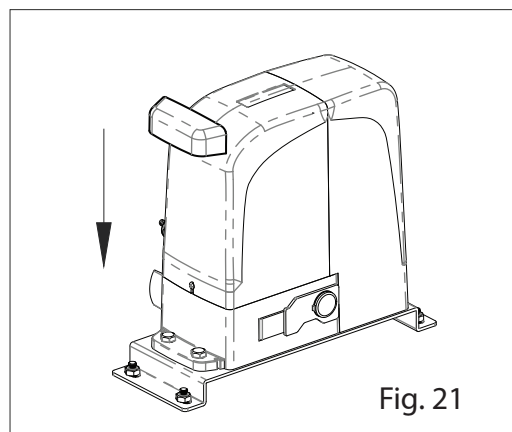

### 7.7. Releasing the operator

Prepare the operator for manual operating mode as described below:  
Insert supplied key on the lock, turn it clockwise 90°, pull and open the manual release.

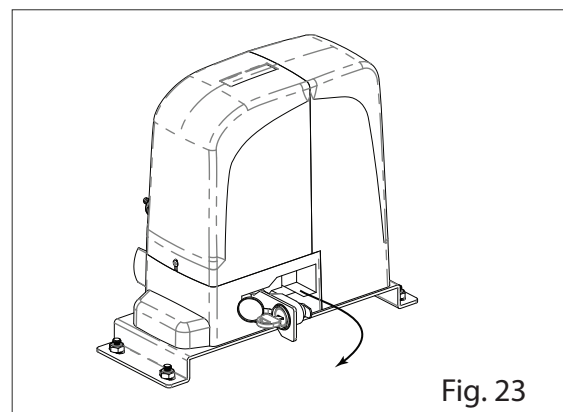
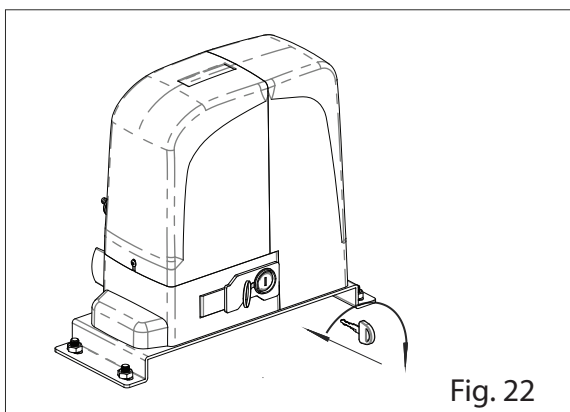

After opened the manual release, you can operate the door manually.

## 7.8. Installing the rack

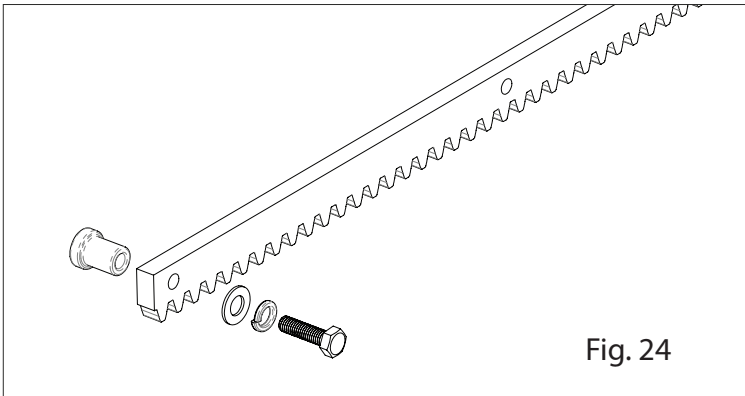

Fig. 24

- Prepare the rack to be applied. Putting these spacers in all holes of the rack in order to be completely secure.

- a) Manually put the gate leaf in the closed position.
- b) Positioning the first rack part to be bolted, supported on the pinion and with help of the level and clamping tool, keep it horizontally leveled.
- c) Move the gate to manually back and forth, to ensure that the gear rack is properly seated on the pinion and movement occurs smoothly.
- d) Set the rack in the gate. (Fig. 21) .To ensure a correct fixation, can go slowly moving the gate and setting the gate spacers always near the pinion.
- e) Pull another element of the rack above, using a piece of additional rack teeth to synchronize the two elements (Fig. 22).
- f) Use a level again to make sure that rack is perfectly level.
- g) Manually move the gate and carry out the operations of attachment such as with the first element, proceeding up to the end of the gate.

NOTE: This motor can work with all types of racks.

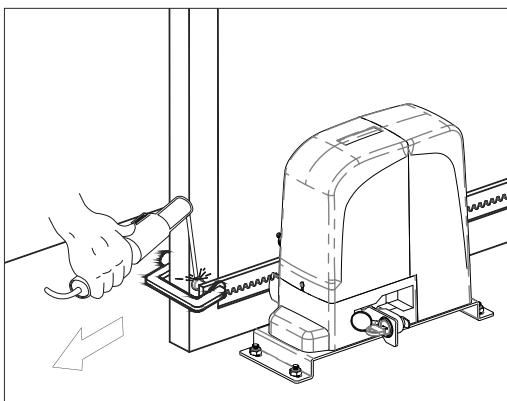

Fig. 25

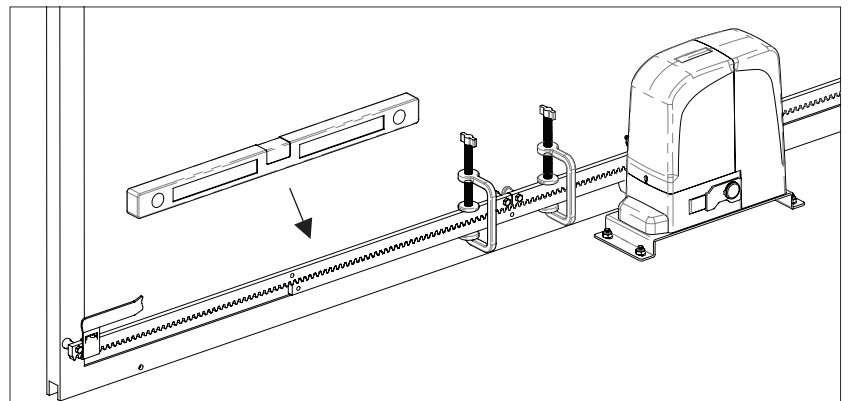

Fig. 26

When installing nylon rack, make the application following the same steps described in the previous paragraphs.

Start by placing the gate in the closed position, support the first meter of rack pinion on the engine and keeping it level horizontally, screw the first screw.

Go opening the gate and tightening the remaining bolts.

Continue adding more rack parts and repeating the same steps to complete the installation.

## NOTES:

- Make sure that, during the gate travel, all the rack elements mesh correctly with the pinion.
- Do not, on any occasion, weld the rack elements either to the spacers. For fixing these, use screws and washers like in the Fig.20.
- Do not use grease or other lubricants between rack and pinion.

## 7.9. Installing limit switch plate

- After having rack installed, take the gate back to the closed position and position the limit switch plate on the rack. In this closed position, the plate should trigger the limit switch of the motor.
- Tighten the screws DIN912 M5x12 included in the pack, until it touches the rack, squeezing it.
- Move the gate to the open position and repeat the same process for the other limit switch plate.

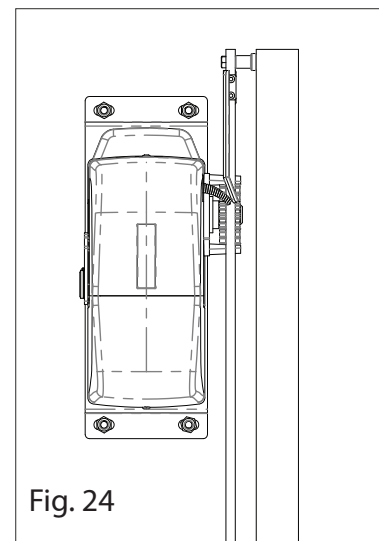
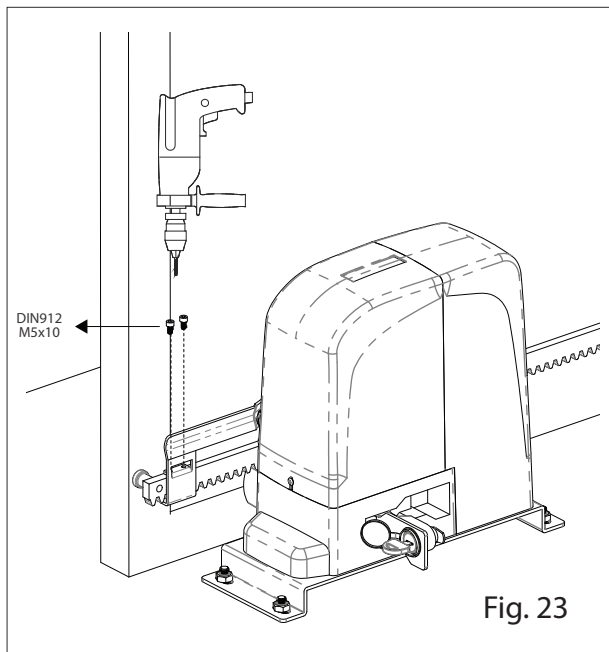

## 8) MAINTENANCE

Carry out the following operations at least every 6 months.

- Check the efficiency of the release system.
- Check the efficiency of the safety devices and accessories.

## 9) REPAIRS

For any repairs, please contact the authorised repair centers.